

SPECIFICATION SHEET NO.	T0310- YLLLF3053A10B1	
ORIGINAL MFR. PART NO.	TGS Crystals -YLLLF3053A10BLF (WEJ324YC-882)	
NEXTGEN ORDER PART NO.	YLLLF3053A10B1	This number is required on all RFQs and Purchase Orders
DATE	Mar. 10, 2026	
REVISION	Rev. A5	Updated to reflect the most recent data
GENERAL DESCRIPTION AND KEY SPECIFICATIONS	<p>3053 Series – 3 mm Yellow LED Lamp with Flange</p> <p>Package Type: 3 mm Round with Flange</p> <p>Package Dimensions: <math>\Phi 3.0 \times 5.3</math> mm</p> <p>Emitting Color: Yellow</p> <p>Viewing Angle: 20°</p> <p>Power Dissipation: 72 mW Max.</p> <p>DC Forward Current: 30 mA Max.</p> <p>Reverse Voltage: 5.0 V Max.</p> <p>Operating Temperature Range: -40°C to +85°C</p> <p>Package: Bulk</p> <p>Compliance: REACH and RoHS (2011/65/EU &amp; 2015/863/EU) compliant</p>	
CUSTOMER		
CUSTOMER PART NO.		
NOTE		

### VENDOR APPROVAL

Prepared by | Checked by | Approved by



Date: Mar. 10, 2026

### CUSTOMER APPROVAL

Signature:

Name:

Title:

Date:

## GENERAL DESCRIPTION

The 3053 Series is a 3 mm round yellow LED lamp with flange for panel mounting and indicator applications. It features a 20° viewing angle and stable optical performance under industrial operating conditions.

## MAIN FEATURES

- 3 mm Round Package with Flange
- Narrow Viewing Angle: 20°
- Stable Optical Output
- Low Power Consumption
- Long Operating Life
- High Reliability – Solid State Device
- Wide Operating Temperature Range
- REACH and RoHS (2011/65/EU & 2015/863/EU) compliant

## APPLICATIONS

- Industrial Control Panels and Instrumentation Indicators
- Power Supply Status Indication and Automation Equipment
- Signal & Status Display
- Commercial Electronic Equipment

## ELECTRICAL CHARACTERISTICS

- Refer to Pages 3–4 for detailed electrical and optical characteristics.

## IMPORTANT NOTICE

- Specifications are subject to change without prior notice.
- NextGen reserves the right to modify product specifications at any time without liability. Customers are responsible for verifying the most current product information prior to design, purchase, or use.
- All parameters and performance data are subject to final confirmation by NextGen.



*The image shown is for reference only. Please refer to the dimensional drawing for exact mechanical specifications.*



**ELECTRICAL CHARACTERISTICS**

*Selection Guide*

Order Part Code	Original Part No.	Emitted Color	Resin Color	Viewing Angle
YLLLF3053A10B1	YLLLF3053A10BLF (WEJ324YC-882)	YELLOW	Clear	20°

*Absolute Maximum Ratings (Ta = 25°C unless otherwise specified)*

Parameter	Symbol	Value	Unit
Power dissipation	Pd	72	mW
DC Forward Current	If	30	mA
Peak Forward Current <sup>(1)</sup>	Ifp	100	mA
Reverse Voltage	Vr	5	V
ESD (HBM, Class 2)	-	2	kV
Operating Temperature	Topr	-40°C to +85°C	
Storage Temperature	Tstg	-40°C to +100°C	
Lead Solder Temperature <sup>(2)</sup>	Tsol	260°C / 5 sec	

Notes:

- 1) 1/10 duty cycle, 0.1 ms pulse width.
- 2) Measured 2 mm below package base.
- 3) ESD Sensitivity Classification: Class 2 (HBM 2kV)
- 4) Exposure to conditions exceeding the absolute maximum ratings may result in permanent device damage.

*Electrical and Optical Characteristics (Ta = 25°C unless otherwise specified)*

Parameter	Symbol	Condition	Value			Unit
			Min.	Typ.	Max.	
Forward voltage	Vf	IF = 20 mA	---	2.0	2.4	V
Luminous intensity	Iv	IF = 20 mA	1000	1700	---	mcd
Dominant wavelength	λd	IF = 20 mA	585	590	595	nm
Peak wavelength	λp	IF = 20 mA	---	592	---	nm
Reverse current	Ir	VR = 5 V	---	---	10	μA

Note:

- 1) Forward Voltage: ±0.1V
- 2) Wavelength: ±1.5nm
- 3) Luminous Intensity: ±10%

TYPICAL ELECTRO-OPTICAL CHARACTERISTICS CURVES

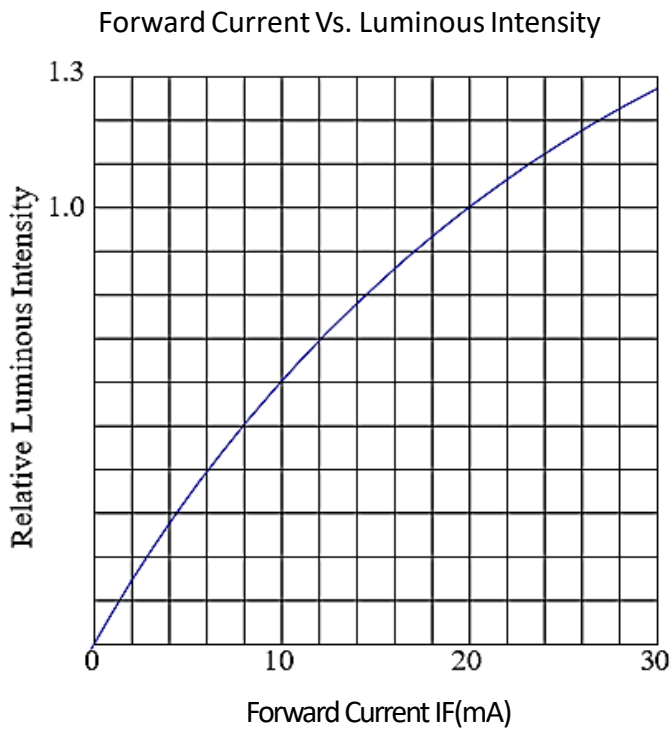
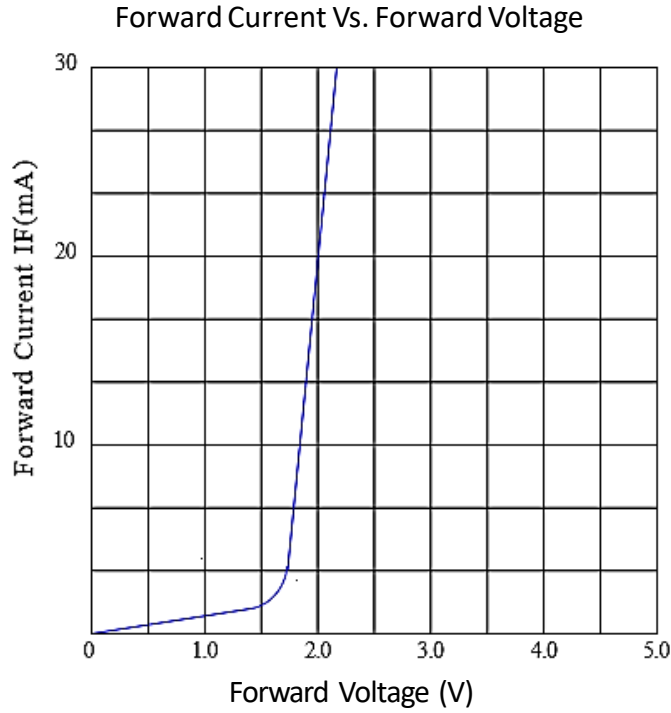

TYPICAL ELECTRO-OPTICAL CHARACTERISTICS CURVES

Ambient Temperature Vs. Forward Current

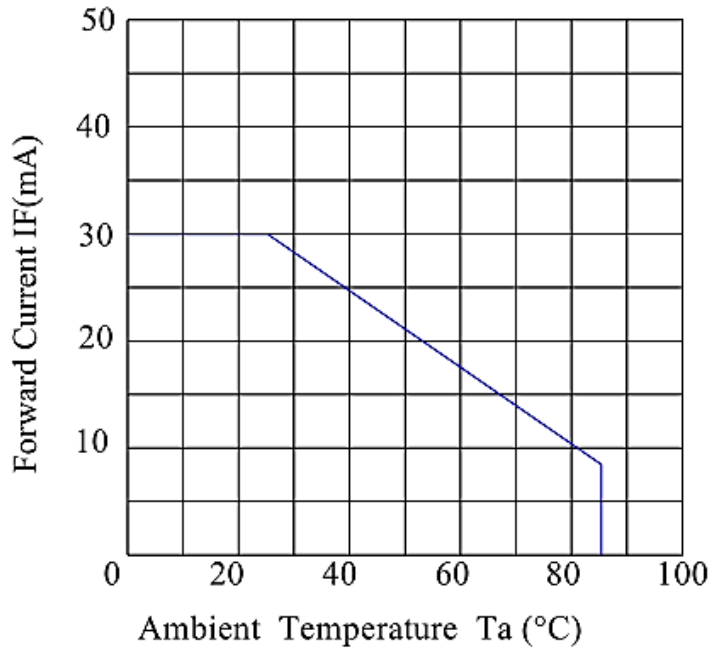

Radiation Diagram

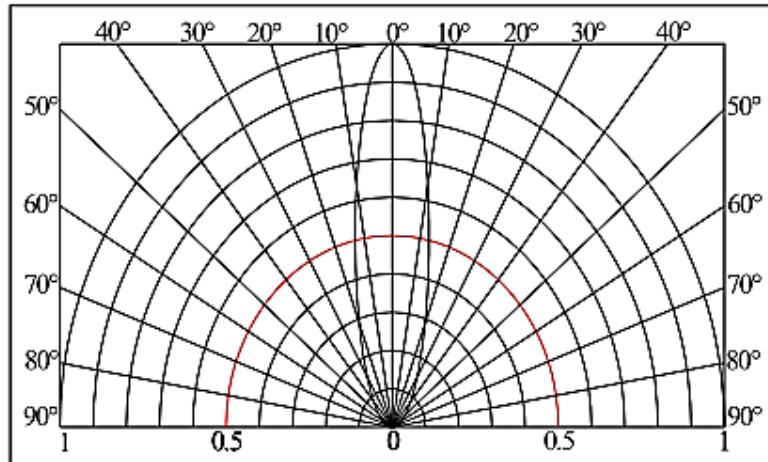

PACKAGE DIMENSIONS - Unit: mm,  $\Phi 3.0 \times 5.3$  mm

- Tolerance is  $\pm 0.25$  unless otherwise noted;
- Lead spacing is measured where the leads emerge from the package

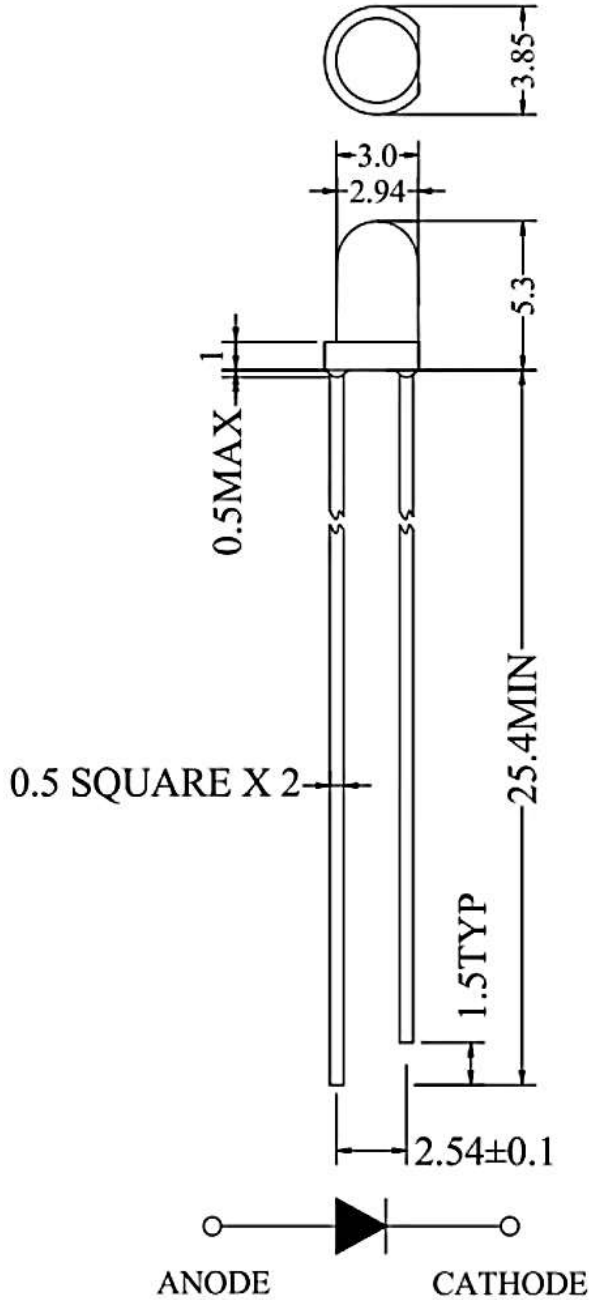

**RELIABILITY TEST ITEMS AND RESULTS**

*Test Item and Result*

Test Item	Ref. Standard	Test Condition	Note	Number of Damaged
Resistance to Soldering Heat	JEITA ED-4701 300-301	Tsld = 260°C, 10 sec	2 times	0/50
Solderability	JEITA ED-4701 300-303	Tsld=215 ± 5°C, 3 sec	1 time, over 95%	0/50
Thermal Shock	JEITA ED-4701 300-307	-40°C, 15 min ↔ 100°C, 15 min	100 cycles	0/50
Temperature Cycle	JEITA ED-4701 100-105	-40°C, 30 min → 100°C, 30 min	100 cycles	0/50
Moisture Resistance Cycle	JEITA ED-4701 200-203	65°C / 25°C / -10°C 90% RH 24 hrs / cycle	100 cycles	0/50
High Temperature Storage	JEITA ED-4701 200-201	Ta = 100°C	1000 hrs	0/50
High Temperature High Humidity Storage	JEITA ED-4701 100-103	Ta = 60°C, 90% RH	1000 hrs	0/50
Low Temperature Storage	JEITA ED-4701 200-202	Ta = -40°C	1000 hrs	0/50
Steady State Operating Life		Ta=25°C, IF = 20 mA	1000 hrs	0/50
Steady State Operating Life of High Temperature		Ta = 85°C, IF = 20 mA	1000 hrs	0/50
Steady State Operating Life of High Humidity Heat		60°C, 90% RH, IF = 20 mA	1000 hrs	0/50
Steady State Operating Life of Low Temperature		Ta = -30°C, IF = 20 mA	1000 hrs	0/50
Drop		H=75 cm	3 cycles	0/50

*Criteria For Judging Damage*

Item	Symbol	Test Condition	Criteria for Judgment	
			Min	Max
Forward voltage	VF	IF = 20 mA	--	U.S.L*) × 1.1
Reverse current	IR	VR=5V	--	U.S.L*) × 2.0
Luminous intensity	IV	IF = 20 mA	L.S.L**) × 0.7	--

Notes:

\*) U.S.L.: Upper Standard Level

\*\*) L.S.L.: Lower Standard Level

## HANDLING AND STORAGE PRECAUTIONS

### *Storage*

LEDs should be stored under the following conditions:

- Temperature:  $\leq 30^{\circ}$  C
- Relative Humidity:  $\leq 60\%$  RH.

Under these conditions, the recommended storage period is 3 months. For extended storage, keep products in sealed containers with moisture-absorbing material. Improper storage may result in lead frame corrosion or degradation of optical performance.

### *Electrostatic Discharge (ESD)*

The device is sensitive to electrostatic discharge. Appropriate ESD protection measures must be implemented during storage, handling, and assembly, including:

- Grounded wrist straps
- Conductive work surfaces
- Anti-static containers and packaging.

### *Circuit Design Considerations*

The forward current must not exceed the specified absolute maximum rating.

Variations in supply voltage may lead to disproportionate increases in forward current, potentially resulting in device failure. Current-limiting resistors must be used in all circuit designs.

Proper thermal management must be considered to prevent degradation of luminous intensity or wavelength shift due to excessive heat.

### *Lead Forming*

Lead forming must be completed before soldering.

Leads should be bent at least 3 mm from the base of the epoxy body.

Avoid repeated bending at the same location, as this may cause mechanical stress and device damage.

Do not use the epoxy body as a mechanical support point during lead forming.

## SOLDERING CONDITIONS

Soldering must be performed under controlled conditions to avoid thermal or mechanical damage.

Recommended Conditions:

- DIP Soldering
- Preheat Temperature:  $\leq 100^{\circ}$  C, 60 sec max
- Solder Bath Temperature:  $250^{\circ}$  C max
- Dipping Time: 5 seconds max
- Distance from Resin Body:  $\geq 2$  mm
- Hand Soldering
- Temperature:  $\leq 350^{\circ}$  C
- Soldering Time:  $\leq 3$  seconds
- Distance from Resin Body:  $\geq 2$  mm

**ORDERING INFORMATION**

- Please refer to the part numbering structure and specify the NextGen order part number YLLLF3053A10B1 on all RFQs and Purchase Orders.

**RFQ**  
[Request For Quotation](#)

**PART NUMBERING STRUCTURE**

Code	Description	Key Specifications
YL	Color	YL: Yellow
LLF	Product Type	LLF: LED Lamp with Flange
3053	Series Code	3053: Package Dimensions: $\Phi$ 3.0 x 5.3 mm
A	Grade Code	A: Grade A
10	Reverse Current Code	10: 10 $\mu$ A
B	Packaging Code	B: Bulk
1	Internal Control Code	Letter A–Z, a–z, or digit (0–9)
XX	Suffix	Blank: Standard; XX: Letter A–Z, a–z, or digit (0–9) for Custom or special specification (if applicable)

COMPARATIVE ELECTRICAL DATA

*For Engineering Reference Only*

*Comparative Electrical & Optical Parameters (Ta = 25°C unless otherwise specified)*

Parameter	Unit	NextGen YLLLF3053A10B1	MFR A Industry Standard	MFR B Industry Standard	MFR C Industry Standard
Package Size	mm	Ø3.0 × 5.3	3 mm Round	3 mm Round	3 mm Indicator
Emitting Color	—	Yellow	Yellow	Yellow	Yellow
Viewing Angle	°	20	15–25	15–25	20
Forward Voltage (Typ.)	V	2.0–2.4	2.0–2.2	2.0	2.0–2.2
Forward Current (Max.)	mA	30	30	30	25–30
Luminous Intensity (Typ.)	mcd	1000–1700	800–1500	700–1400	700–1300
Dominant Wavelength	nm	588–595	588–595	588–592	585–595
Operating Temp. Range	°C	–40 to +85	–40 to +85	–40 to +85	–40 to +85
ESD (HBM)	kV	2	2	2	2

Note:

- Comparative information is provided for engineering reference only and does not imply guaranteed interchangeability.
- Operating temperature range may vary by manufacturer.

### *Functional Compatibility Summary*

This product is designed to be functionally comparable to the above referenced series in terms of:

- Mechanical form factor
- Electrical characteristics
- Optical performance
- Environmental operating capability

Suitable for indicator and panel mounting applications in industrial and commercial equipment.

### *Substitution Disclaimer*

- Comparative information is provided for engineering reference only and is based on publicly available specifications.
- This document does not imply guaranteed interchangeability or direct equivalence.
- Customers are responsible for validating mechanical fit, electrical performance, thermal behavior, and application suitability prior to product substitution.
- NextGen assumes no liability arising from product substitution or application-specific implementation.

## IMPORTANT NOTES AND DISCLAIMER

### *RoHS Compliance*

This product complies with EU RoHS Directive 2011/65/EU and its amendment (EU) 2015/863 (RoHS 3). Restricted substances are below applicable threshold limits or permitted under exemptions. RoHS documentation is available upon request.

### *REACH Compliance*

Information regarding Substances of Very High Concern (SVHCs) under REACH is available. As the European Chemicals Agency (ECHA) periodically updates the SVHC list, customers should obtain the latest information prior to use.

### *Product Performance*

All parametric performance data is specified under the electrical characteristics and corresponding test conditions provided herein, unless otherwise noted. Performance may vary if operated outside specified conditions.

### *Specifications and Changes*

NextGen Components, Inc. ("NextGen") reserves the right to modify this document and the products described herein at any time without prior notice. Customers are responsible for verifying the most current product information prior to final design, purchase, or use.

### *Warranty and Limitation of Liability*

*NextGen* makes no representation or warranty, express or implied, regarding suitability for any particular purpose. *NextGen* shall not be liable for any indirect, incidental, consequential, or special damages arising from product use. No license is granted under any intellectual property rights of *NextGen*.

### *Restricted Applications*

*NextGen* products are not authorized for use as critical components in life-support devices, medical systems, or other safety-critical applications without prior written approval.

### *Returns Policy*

Customers must obtain a Returned Merchandise Authorization (RMA) number before returning products. Returns must be requested within 30 days of invoice date and products must be unused and in original packaging. Products designated as Non-Cancelable / Non-Returnable (NCNR) are not eligible for return.